

- (1) **Application** This specification applies to the soldering process of related electronic components of electronics and products.
- (2) **Appearance and Dimension**

Figure (1) Wire Cross Section

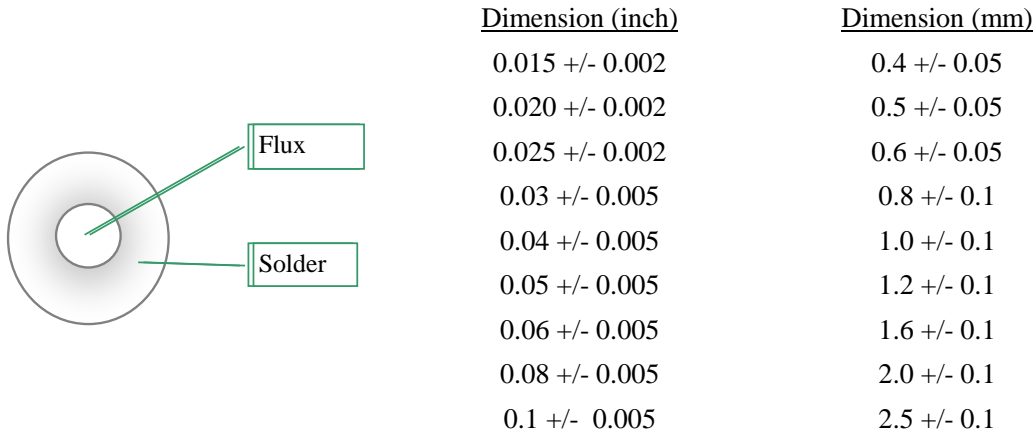
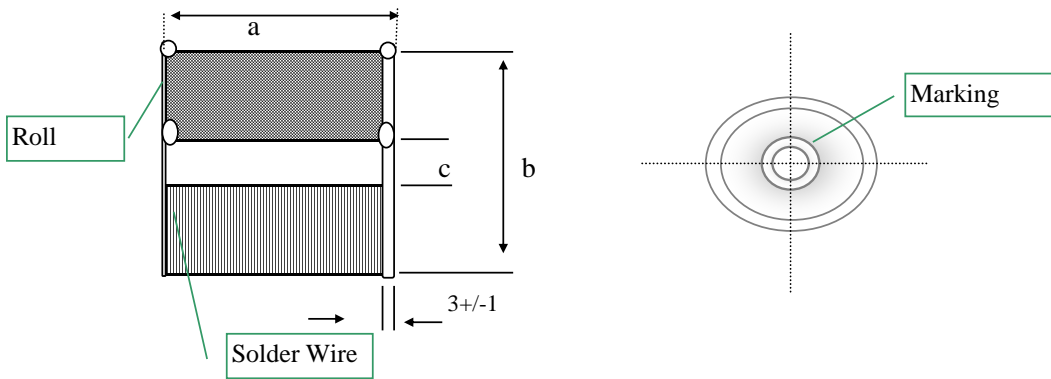

Figure (2) Roll Shape



Net Weight/Roll	Dimension		
	a	b	c
0.5Kg	65mm	72mm	39mm
1Kg	65mm	72mm	20mm
5Kg	111mm	147mm	22mm

(3) Characteristics

3.1 Alloy Composition and Flux Cont

Item	Specification					
	Composition(%)	Impurity (%)				
Solder	Sn	Ag	Pb	Sb	Zn	Fe
	Bal.	<0.1	<0.05	<0.1	<0.001	<0.02
	Cu	As	Bi	Cd	Al	
	0.7+/- 0.2	<0.03	<0.1	<0.002	<0.001	
Flux	1688		Flux Content		2.5 ~ 3.0%	

3.2 Physical Characteristic

Alloy Designation	Melting Point	Specific Gravity
Sn/0.7Cu	227°C	7.31g/cm ³

3.3 Characteristics of Flux and Solderability

Item	Specification	Test Methods
Flux Type	ROL1	IPC J-STD-004
Dryness	The surface of the residue shall be free from tackiness permitting easy removal.	JIS Z 3197
Copper Plate Corrosion	No Evidence corrosion.	IPC TM650 2.6.15
Copper Mirror	No Evidence of mirror breakthrough.	IPC TM650 2.3.32
SIR Value	$>1 \times 10^8$	IPC TM-650 2.6.3.3
Spread	>75%	JIS Z3197

- (4) **Working Temperature** Recommended temperature of soldering iron tip : 370~430°C
(According to different dimension, adjust the suitable temperature of soldering)
- (5) **Standard Packaging** Flux cored halogen-free solder wire should be coiled to the roll and package with 10 rolls (0.5kg/roll or 1kg/roll) in one box (5kg/box or 10kg/box).
- (6) **Validity and Storage** 1 year in right storage.
Store in cool place and keep away from direct sunlight or fire place.

岱暉股份有限公司

DYFENCO International Co., Ltd.

<http://www.dyfenco.com>

No. 136, Silin Road, Yanchao Dist., Kaohsiung City, 82446 Taiwan

Tel +886-7-616 0317

Fax +886-7-616 1639